

## new smart

### Tavoli per Pizzeria GN



I banchi per pizzeria GEMM sono progettati per soddisfare tutte le esigenze del mercato e dotati di impianti refrigeranti appositamente studiati per garantire la perfetta conservazione della palline della pizza.

La serie NEW SMART è una gamma di tavoli di preparazione per locali pizzerie e fast-food, con dimensioni di ingombro molto contenute.

I banchi per pizzeria NEW SMART si caratterizzano per la base refrigerata con dimensioni interne GN 1/1, piano in granito sardo con alzatine posteriori h 160 mm e vetrina refrigerata portabacinelle con gruppo indipendente corredata di mensola in vetro diritto.

Bacinelle GN escluse.

#### DATI TECNICI:

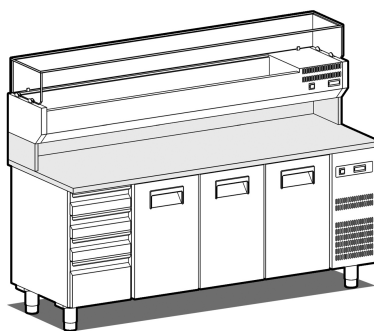

#### SMR/20C

Dimensioni esterne (WxDxH)	mm	2000x720x1500
Capacità	lt	350
Dotazioni (griglie)	nr	3 GN 1/1
Capacità bacinelle vetrina refrigerata	nr	9 GN 1/3
Potenza max assorbita *	W	200 + 155
Potenza refrigerante *	W	362 + 280
Temperatura tavolo refrigerato	°C	+2/+8
Temperatura vetrina refrigerata	°C	+2/+8
Gas		R290
Tensione alimentazione		1x230V-50Hz
Classe climatica		5

\*Evap. -10°C cond. +45°C



## ACCESSORI E MAGGIORAZIONI A RICHIESTA:



Coppia guide GN 1/1

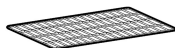

Griglia GN 1/1

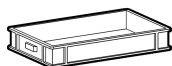

Cassetta in plastica GN 1/1

Coperchio cassetta in plastica GN 1/1



Ruota pivotante Ø 125 mm

Ruota autobloccante Ø 125 mm

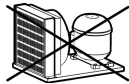

Versione predisposta con impianto a valvola (detrazione)



Sistema supervisione Wi-Fi (maggiorazione)



Frequenza 60Hz



KIT/20

Kit bacinelle inox GN + coperchi



CRE/2

Cassettiera refrigerata a 2 cassetti 1/2

SCHEMA DI INSTALLAZIONE:

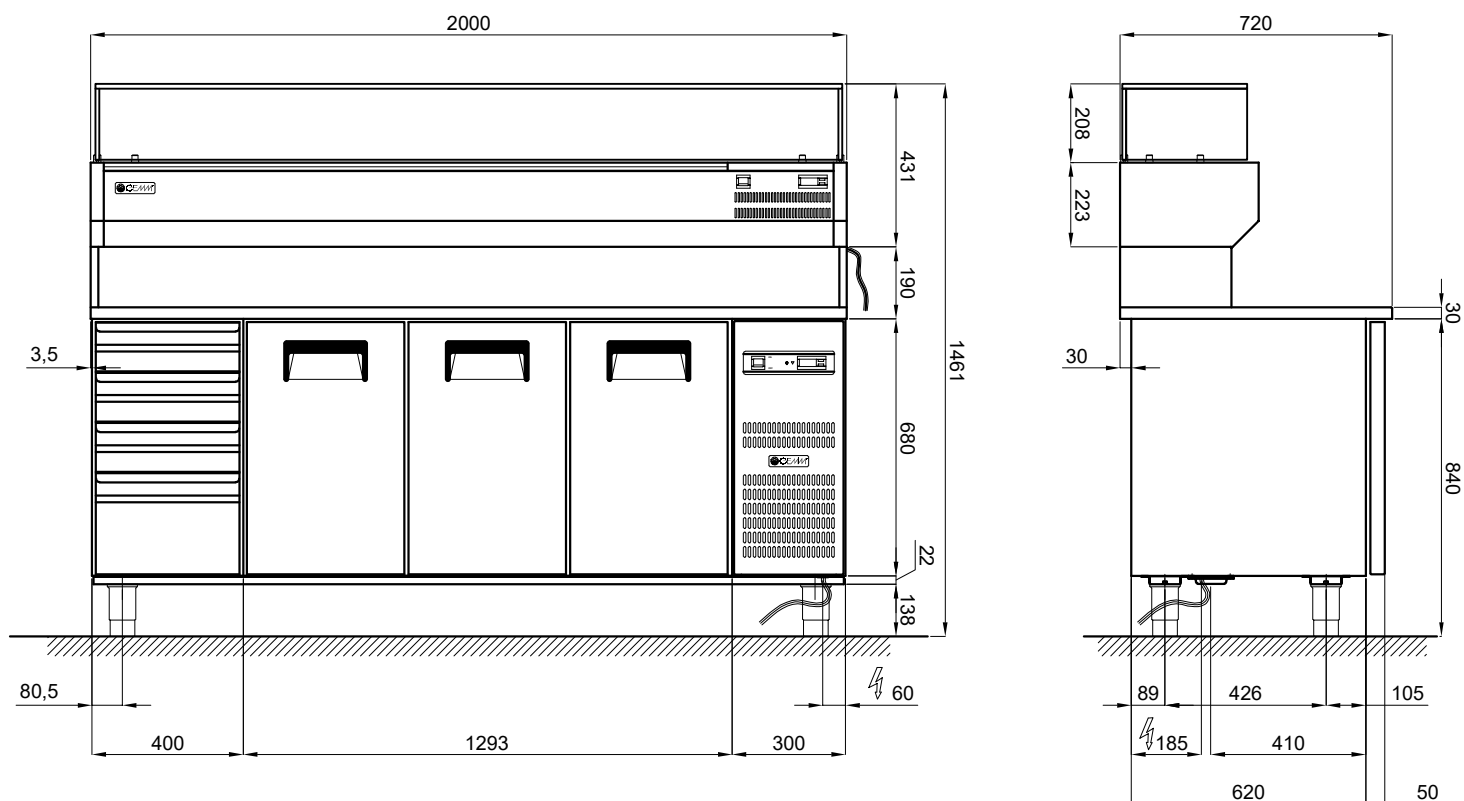

ALIMENTAZIONE : 230 V ~ 1 - 50Hz (\* spina SHUKO) - Lunghezza cavo 1.5 mt



ALIMENTAZIONE : 230 V ~ 1 - 50Hz (\* spina SHUKO) - Lunghezza cavo 2 mt

PART.  
INGOMBRO PORTE  
SCALA 1 : 50

